

## Device and method for thermal diffusivity analysis

CSIC through the Institute of Materials Science of Barcelona ICMAB has developed a new device suitable to study thermal transport with enhanced sensitivity to in-plane heat flow.

Industrial partners are being sought to collaborate through a co-development project and a patent license agreement.

### An offer for Patent Licensing

#### Device and method for in-plane thermal transport study

The study of in-plane thermal transport in bulk and low dimensional anisotropic materials is going to be crucial in next years as these materials are incorporated in applications such as electronics, thermoelectrics, and heat management devices.

The current devices and methods are complex, and may be influenced by the shape of the heat source and/or are mostly suitable for electrically insulating samples.

We present a new contactless device and method for studying thermal transport with enhanced sensitivity to in-plane heat conduction, which is based on beam-offset frequency-domain thermoreflectance using a one-dimensional heat source with uniform power distribution. The method has been validated for free standing films, bulk samples (e.g. anisotropic crystals and substrates) and thin films on a substrate.

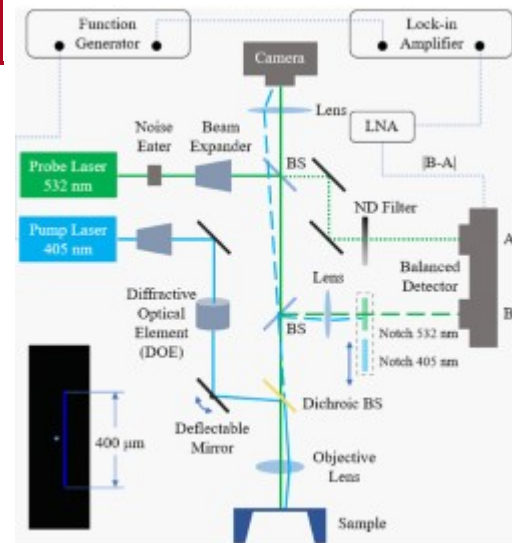

Scheme of the device

#### Main innovations and advantages

- The typical high precision and accuracy of thermoreflectance now applicable to anisotropic materials.
- Enhanced sensitivity to in-plane heat transport allows new alternatives to study in-plane thermal transport in thin films and 2D materials.
- No dependence of the data on the spatial energy distribution of the heat source.
- Contactless approach based on the use of lasers.
- Applicable to electrically insulating and conducting samples.
- Three operation modes to study the specimens available: (i) without metallic thin film transducer, (ii) with metallic transducer for samples with high thermal conductivity, and (iii) with patterned transducer for samples with lower thermal conductivity.
- Strongly simplified and robust data analysis procedures.

#### Patent Status

Patent application filed suitable of international extension

#### For more information, please contact:

Alfonso del Rey

Institute of Materials Science of  
Barcelona ICMAB

Spanish National Research Council  
(CSIC)

Tel.: +34 935801853

E-mail: adelrey@icmab.es  
comercializacion@csic.es